

GLOBAL JOURNAL OF ENGINEERING SCIENCE AND RESEARCHES

REDUCTION OF ICI IN OFDM USING BLACKMAN GAUSSION AND HANN WINDOW FUCTIONS

PRATEEK NIGAM^{*1}, ALOK KUMAR DUBEY², Dr. VIJAYSHRI CHAURASIA³

Phd scholar, AISECT UNIVERSITY, Bhopal^{*1}

M.Tech Scholar, EC Department, RKDFIST, Bhopal²

Asst. Professor, MANIT, Bhopal³

ABSTRACT

In Orthogonal Frequency Division Multiplexing (OFDM) carriers are orthogonally related and hence no guard band is necessary like in Frequency Division Multiplexing (FDM). So spectrum's of users can overlap which enhances the spectrum efficiency of the network. In this thesis one of the main concern of OFDM, inter carrier interference (ICI) is considered using different window functions in frequency domain in pulse shaping of OFDM data symbols which are considered uncorrelated. It reduces the inter carrier interference (ICI) power into simply the square magnitude of window function. Here we have taken different window functions for comparing performance of the wireless links in content of ICI power and desired received signal. Orthogonal Frequency Division Multiplexing (OFDM) is technique of multi-carrier modulation in which a single high rate data-stream is first divided into multiple low rate data-streams and is then modulated using sub-carriers. These sub-carriers are orthogonal to each other. Its main advantages are multipath delay spread tolerance, high spectral efficiency, immunity to Frequency Selective Fading Channels, efficient modulation and demodulation process which is performed by computationally efficient Inverse Fast Fourier Transform (IFFT) and Fast Fourier Transform (DFT) operation respectively. An important disadvantage of OFDM is the carrier frequency offset which disturbs the orthogonality among the carriers and results Inter carrier interference (ICI). The undesired ICI degrades the performance of the system.

Keywords: — Frequency Spectrum, SIR, Power of Desired Signal, Fading and AWGN, OFDM, ICI.

I. INTRODUCTION

Orthogonal Frequency Division Multiplexing (OFDM) is a multi-carrier modulation technique, in which a single high rate data-stream is first divided into multiple low rate data streams and is then modulated using sub-carriers which are orthogonal to each other [3]. Major advantages of OFDM are its multi-path delay spread tolerance and efficient spectral usage by allowing overlapping in the frequency domain. Also another significant advantage is that the modulation and demodulation can be done in computationally efficient way using IFFT and FFT operations [4]. In addition to above, OFDM has several favorable properties like high spectral efficiency, robustness to channel fading, immunity to impulse interference, uniform average spectral density, capacity to handle very strong echoes and non-linear distortion [5, 6]. Hence in multi-carrier modulation, the most commonly used technique is Orthogonal Frequency Division Multiplexing (OFDM) which has recently become very popular in wireless communication. OFDM is a promising modulation technique which can be used in many new broadband communication systems.

One of the major limitations of OFDM systems is Inter Carrier Interference (ICI). OFDM system is exposed to the risk of being attacked or harmed by frequency-offset errors between the transmitted & received signals, which may be due to Doppler shift in the channel or by difference between the transmitters and receiver local oscillator frequencies. Hence subcarriers will be no more orthogonal to each other which results in inter-carrier interference (ICI). If ICI should be properly compensated otherwise it will result in power leakage among the subcarriers and orthogonality between them will be lost which results in degradation of system performance.

II. WINDOW FUNCTION BASED OFDMA

A. OFDM Signal on Continuous Time Axis

In OFDM each sub-carrier is modulated independently with complex modulation symbol vector. Let us consider an OFDM signal consists of N subcarriers spaced by f Hz. The k^{th} subcarriers for symbol duration $[0, T]$ is expressed as,

If there are N different users i.e. N sub-carriers OFDM system, n^{th} signal block is represented as,

Where $S_{n,k}$ is the constellation vector of k^{th} sub-carrier in n th block.

Entire continuous time signal,

The constellation vector $S_{n,k}$ of k^{th} sub-carrier is recovered by using cross correlation of following equation [1-2],

Where

At receiving end constellation vector is retrieved like,

where $r_n(t) = S_{n,k} n(t)$ is the noisy received signal and $n(t)$ is AWGN of environment.

B. Window Functions in OFDM

The ideal impulse response of a linear time invariant (LTI) system may extends over an infinite duration which can make the system complicated in determining response of the system. To make the impulse response $h(t)$ of infinite duration to an effective finite duration impulse response $h_D(t)$, a pulse $p(t)$ of finite duration is multiplied with $h(t)$ to truncate the portion beyond $p(t)$.

Let $h(t) = \text{Asinc}(ct)$ is an impulse response of a system of infinite duration.

Let us multiply $h(t)$ with a rectangular pulse, $P(t) = \text{rect}(t/\tau)$ to get a practical impulse response, $h_D(t) = h(t) \cdot p(t)$. Truncation of any signal very sharply provides huge ripples in frequency domain. To combat the situation of any ideal impulse response is multiplied by smooth function called window function. That results truncation of impulse response by a smooth window function.

C. Reduction of ICI in OFDM

Let the data symbol of an OFDM block of size of N are $\{d_k\}$. The complex envelop of the N sub-carrier OFDM,

Where f_k is the k^{th} sub-carrier and $p(t)$ is the pulse shaping function over a symbol period.

The final modulated block,

Where f_c is the carrier frequency.

If the data symbol are uncorrelated,

Considering received signal frequency offset of f' and a phase error of Φ the received signal after coherent demodulation with carrier f_c ,

Now n th sub-channel coherent demodulator gives [41],

Where

The first part of the equation is desired signal and the second part is ICI signal.

Now power of desired signal, and that of ICI power,

Since data symbols are uncorrelated.

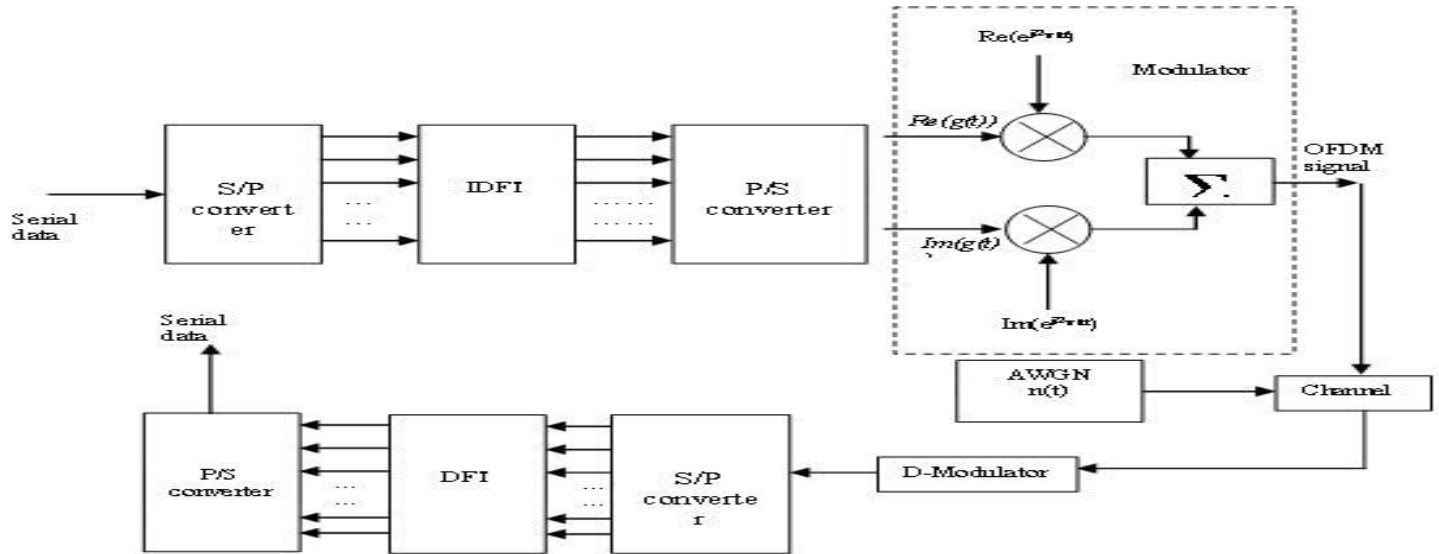

Fig. 1 OFDM communication system

III. RESULTS

This section will analyze the performance of OFDM system where window function based symbols are used as the base band signal. Three different window functions named Blackman, Gaussian and Hann are used for comparison. We plot the power of desired signal, power of ICI signal and signal to interference ratio (SIR) against the frequency offset for each window function case.

Fig. 2 compares the power of desired signal against frequency offset for Blackman, Gaussian and Hann window function case. Power of desired signal is higher at smaller frequency offset values and decreases with increasing frequency offset. Desired power is maximum for Hann Window function case and minimum for Blackman window function case.

In Fig. 3 inter carrier interference (ICI) is compared for the three window functions. Blackman have the lowest power of ICI and Gaussian has the highest power of ICI. Power of ICI signal is increasing with increasing the frequency offset for all window functions and converges at frequency offset above 0.85.

Finally in Fig. 4 signal to interference ratio (SIR) is compared for the same three window functions with variation of frequency offset. Here Gaussian has the best performance for frequency offset below 0.55 as its SIR varies slowly within frequency offset of 0 to 0.55 but above that range Blackman shows the best performance.

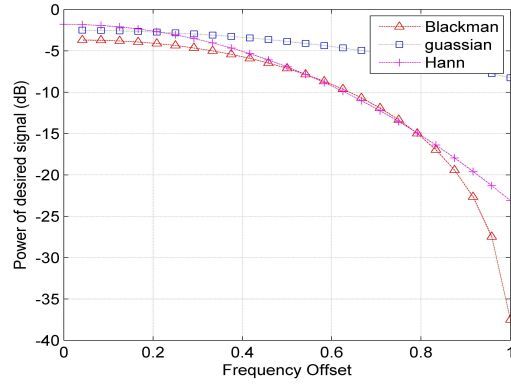

Fig. 2

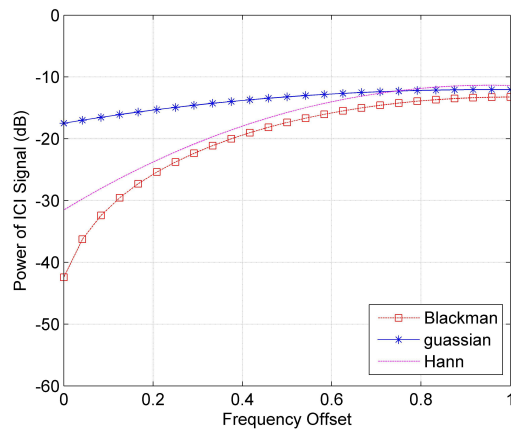

Fig. 3

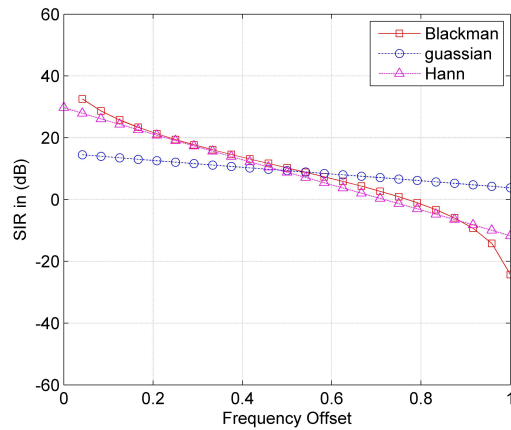

Fig. 4

IV. CONCLUSION

In this paper three different widely used window functions are used as the envelope of OFDM symbols and their relative performance in context of power of desire signal, power of ICI and SIR are discussed in result sections. Still there is a scope of incorporation of ‘Raised Cosine Pulse’ for the same analysis to observe whether its performance is better than or not the existing window functions. Here only frequency offset and phase error is considered as the impact of wireless channel but the entire work can be extended for Raleigh or Rician fading channel including AWGN.

V. REFERENCES

- [1] Md. Al- Mahadi Hasan, Shoumik Das, Md. Imdadul Islam, and M. R. Amin, “REDUCTION of ICI in OFDM USING WINDOW FUNCTIONS”, 2012 7th International Conference on Electrical and Computer Engineering, 20-22 December, 2012, Dhaka, Bangladesh.
- [2] R.W Chang, “Synthesis of Band-Limited Orthogonal Signals for Multi-channel Data Transmission,” *Bell Syst. Tech.*, Vol.45, pp.1775-1797, Dec. 1966.
- [3] R.W Chang, “Orthogonal Frequency Division Multiplexing,” U.S Patent 3388455, Jan 6, 1970, Filed Nov.4.1966.
- [4] B.R. Satzberg, “Performance of an Efficient Parallel Data Transmission System, *IEEE Trans. Commun. Technol.*, Vol.COM-15, no.6, pp. 805-811, Dec 1967.
- [5] S. Weinstein and P. Ebert, “Data Transmission by Frequency Division Multiplexing Using the Discrete Fourier Transform,” *IEEE Transaction of Communication*, Vol.19, and Issue: 5, pp. 628–634, Oct.1971.
- [6] B. Hirosaki, “An Analysis of Automatic Equalizers for Orthogonally Multiplexed QAM Systems,” *IEEE Transaction Communication*, Vol.28, pp.73-83, Jan.1980.
- [7] B. Hirosaki, S.Hasegawa, and A. Sabato, “Advanced Group-band Data Modem Using Orthogonally Multiplexed QAM Technique,” *IEEE Trans. Commun.* Vol. 34, no. 6, pp. 587-592, Jun. 1986.
- [8] M. A. Saeed, B. M. Ali and M. H. Habaebi, “Performance evaluation of OFDM scenes over multipath fading channel”, in *The Asia-Pacific Conference on Communications (APCC)*, Malaysia, 2003, pp. 415-419.
- [9] J. Armstrong, “Analysis of new and existing methods of reducing inter carrier interference due to carrier frequency offset in OFDM,” in *IEEE Trans. Communication.*, vol. 47, pp. 365-369, Mar. 1999.
- [10] A. Peled and A. Ruiz, “Frequency Domain Data Transmission using Reduced Computational Complexity Algorithms,” *Acoustics, Speech, and Signal Processing, IEEE International Conference on ICASSP '80*, Vol. 5, pp.964 – 967, Apr. 1980.
- [11] M.S Zimmerman and A.L Kirsch, “The AN/GSC-10 (KATHRYN) Variable rate data modem for HF radio,” *IEEE Trans. Commun. Technol.*, Vol.15, no.2, pp. 197-205, Apr. 1967.
- [12] W.E. Keasler, Jr., “Reliable Data Communications over the Voice band-width Telephone Using Orthogonal Frequency Division Multiplexing,” *Ph.D. dissertation, Univ. Illinois, Urbana, Il*, 1982.
- [13] L. J. Cimini, “Analysis and Simulation of a Digital Mobile Channel using Orthogonal Frequency Division multiplexing,” *IEEE Transaction Communications*, Vol.33, pp. 665-675. July 1985.